

POST PROTECTOR SHALLOW PROFILE

Handle-It® Post Protectors are designed as an economical way to protect racking from manually transferred materials. Installation is easy and can be used in many rack protecting applications. Handle-It® yellow powder-coated paint makes the post protector easily seen.

Features and Benefits

- Handle-It® Post Protectors help prevent damage to rack uprights, shelving uprights, partitions, and many other factory and warehouse structures.
- These heavy steel protectors provide a low cost method of reducing damage to expensive equipment and protecting personnel from falling rack structures hit by moving machinery.
- Handle-It® Post Protectors wrap around the 3" vertical member to be protected, closely fitting- yet protecting- the upright from damage from collisions with forklifts or other moving vehicles.
- These heavy duty 1/4" thick steel protectors are easily mounted by securing to the concrete floor using two 1/2" diameter wedge anchors (supplied as optional purchase).
- A variety of standard heights are available with custom heights available on special order.
- Handle-It® Post Protectors are painted in safety yellow with a hard glossy finish for a durable and attractive appearance.

Guarantee and Warranty

Personal and professional customer service is offered on all Handle-It® Post Protectors. Our Post Protection carries a one-year limited warranty on all materials and workmanship.



Shallow Profile Post Protector

Your Company Information

SHALLOW PROFILE POST PROTECTOR DIMENSIONS

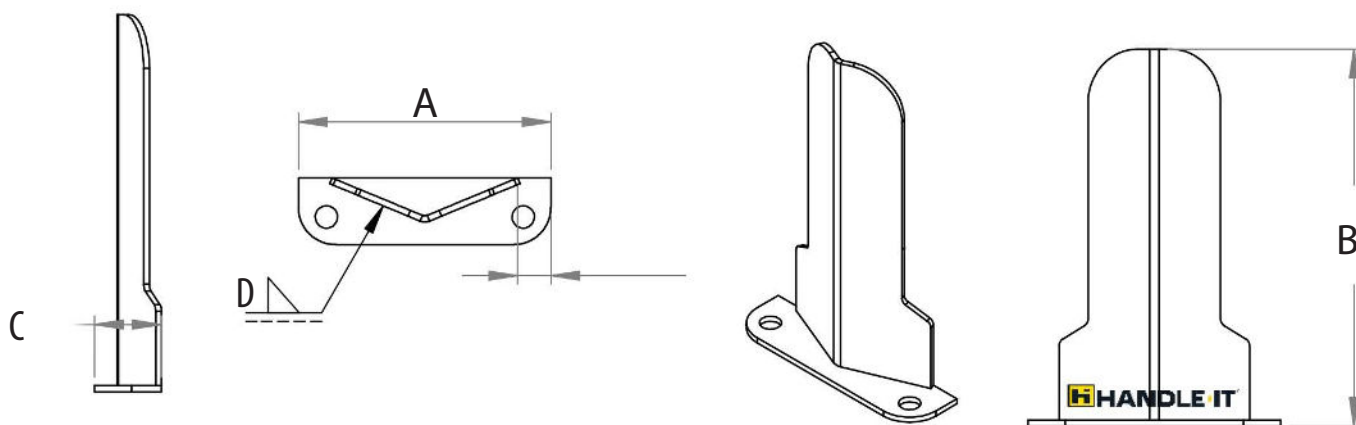

Part	A	B	C	D	E
	Overall Width	Overall Height	Guard Depth	Guard Thickness	Guard to Edge
P12-SP	8"	12"	2"	1/4"	1.06"
P18-SP	8"	18"	2"	1/4"	1.06"

Post Protector Selection Guide

Protection Equipment Specification

In order to select the correct size:

- Measure across foot plate of rack application.
- Select desired height (refer to column B).
- Do columns need to be offset on the base plate or is the column to be placed in the corner of the base plate? (Tight space conditions govern this decision.)

Custom protection is our specialty. If your requirements are not listed in the above specifications, please contact us. Our design team will develop a quick and economical solution to your protection needs.